



# CE **Instruction manual**

Air operated diaphragm pumps

**topflo**<sup>®</sup>

Aseptic pumps in  
stainless steel AISI 316L



- ▶ Instructions for installation, start up, operation, maintenance and repair
- ▶ Spare parts



**Read this instruction manual carefully, before you install and operate the pump**

# ▶ CONTENTS

<b>Ch.</b>	<b>Content</b>	<b>Page</b>	<b>Ch.</b>	<b>Content</b>	<b>Page</b>
	<b>CE CERTIFICATE</b>	<b>3</b>	<b>5.</b>	<b>DATA</b>	<b>14</b>
<b>0.</b>	<b>GENERAL</b>	<b>4</b>	5.1	Capacity curves	14
0.1	Introduction	4	5.2	Capacity changes	14
0.2	The warning symbols	4	5.3	Dimensions and technical data	15
0.3	EHEDG certification	4	5.4	Tightening torques	15
<b>1.</b>	<b>INSTALLATION</b>	<b>5</b>	<b>6.</b>	<b>WARRANTY &amp; REPAIR</b>	<b>16</b>
1.1	Receiving inspection	5	6.1	Returning parts	16
1.2	Storage	5	6.2	Warranty	16
1.3	Foundation	5	6.3	Warranty form	18
1.4	Suction and discharge pipings	5		<b>NOTES</b>	<b>19</b>
1.4.1	Connection of suction pipe	5			
1.4.2	Connection of discharge pipe	5			
1.4.3	Optimizing the pipework layout for drainability	5			
1.5	Air connection	5			
1.5.1	Air treatment system	6			
1.6	Example of installation	6			
1.7	Recommended installations	6			
1.7.1	Flooded	6			
1.7.2	Selfpriming	6			
<b>2.</b>	<b>OPERATION</b>	<b>7</b>			
2.1	Health and safety	7			
2.1.1	Protection	7			
2.1.2	Environments in danger of explosion	7			
2.1.3	Air pressure	7			
2.1.4	Noise level	7			
2.1.5	Temperature hazards	7			
2.2	Before starting the pump	7			
2.3	Starting and operating	8			
2.3.1	Dry running	8			
2.3.2	Optimizing the pump lifetime	8			
2.4	Pump stopping	8			
2.5	Cleaning of the pump	8			
2.5.1	CIP - Clean in place	8			
<b>3.</b>	<b>MAINTENANCE</b>	<b>9</b>			
3.1	Performance test	9			
3.2	Routine inspection	9			
3.3	Complete inspection	9			
3.4	Location of faults	9			
3.7	Dismantling the pump	10			
3.7.1	Before the dismantling procedure	10			
3.7.2	Mainparts	10			
3.7.3	Center block	10			
3.8	Assembly of the pump	11			
3.8.1	Center block	11			
3.8.2	Assembling of the main units	11			
3.8.3	Test run	11			
<b>4.</b>	<b>SPARE PARTS</b>	<b>12</b>			
4.2	TX94 and TX144 - Drawing and spare part list	12			
4.3	Stocking recommendation	13			
4.4	How to order parts	13			
4.5	Pump code	13			

## **Declaration of conformity**

**Machinery directive 2006/42/EEC, Annex 2A**

Tapflo AB declares that:

Product name: **Air operated diaphragm pumps**  
Models: **T...**

Is in conformity with the essential health and safety requirements and technical construction file requirements of the EC Machinery directive 2006/42/EEC, amended from directive 95/16/EEC.

Manufacturer: Tapflo AB

Address: Filaregatan 4  
S-442 34 Kungälv  
Sweden

Tapflo AB, January 2nd 2010



Håkan Ekstrand  
Managing director

# ▶ 0. GENERAL

## 0.1 Introduction

The Tapflo Air Operated Diaphragm Pump range is a complete series of pumps for industrial applications. The pumps are designed to be safe simple and easy to use and maintain. The construction is sealless and without rotating parts. The pumps are suitable for a variety of duties in hygienic installations.

With proper attention to maintenance, Tapflo Pumps will give efficient and trouble free operation. This instruction manual will familiarise operators with detailed information about installing, operating and maintaining the pump.

## 0.2 The warning symbols

The following warning symbols are present in this instruction manual. This is what they say.



This symbol stands next to all safety instructions in this instruction manual where danger to life and limb may occur. Observe these instructions and proceed with utmost caution in these situations. Inform also other users of all safety instructions. In addition to the instructions in this instruction manual, the general safety and accident prevention regulations must be observed.



This signal stands at points in this instruction manual of particular importance for compliance with regulations and directives, for correct work flow and for the prevention of damage to and destruction of the complete pump or its subassemblies.

## 0.3 EHEDG certification

The Tapflo Aseptic series is EHEDG certified by the Danish Technological Institute. The EHEDG certification comprise both a hygienic design evaluation as well as CIP cleanability tests. Our aseptic pump TX94 was certified in April 2009.



# ▶ 1. INSTALLATION

## 1.1 Receiving inspection

Although precaution is taken by us when packing and shipping, we urge you to carefully check the shipment on receipt. Make sure that all parts and accessories listed on the packing list are accounted for. Immediately report any damage or shortage to the transport company and to us.

## 1.2 Storage



If the equipment is to be stored prior to installation, place it in a clean location. Do not remove the protective covers from the suction, discharge and air connections which have been fastened to keep pump internals free of debris. Clean the pump thoroughly before installation.

## 1.3 Foundation



The support of the pump is furnished with mounting holes. Fix the pump on a stable foundation, which is able to absorb vibrations. It is essential for the operation of the pump to mount the pump with the feet in a downward direction (see sketch in chapter 1.6).

## 1.4 Suction and discharge pipings

Suction and discharge piping should be fully supported and anchored near to but independent of the pump. The piping to the pump should be a hose, to prevent undue stress and strain on the pump connections and the pipings.

### 1.4.1 Connection of suction pipe

Remember that the suction pipe/connection is the most critical point, especially if the pump is priming. Just a small leakage will dramatically reduce the suction capability of the pump. When connecting the suction pipe, following is recommended.

- 1) For satisfactory operation, use reinforced hose (the suction power may otherwise shrink the hose) or other flexible piping. The internal diameter of the hose should be the same as on the suction connection (at the bottom of the pump) to have best suction capability.
- 2) Make sure that the connection hose - pump is completely tight, otherwise the suction capability will be reduced.
- 3) Always use as short suction pipe as possible. Avoid air pockets which can arise with long pipings.

### 1.4.2 Connection of discharge pipe



For this connection it is only recommended a simple and positive flow connection. Use a hose or flexible piping (minimum one meter) between the discharge connection and any rigid fixed piping. Coil the hose at least one turn. All components (hose, pipe, valves etc) on the discharge piping must be designed for minimum PN 10.

### 1.4.3 Optimizing the pipework layout for drainability

The pump is designed to follow the EHEDG regulations, where one of the most important factors is the drainability. Apart from the pump it is also important that the whole pipe system is drainable. Horizontal surfaces must be avoided, as a general rule pipes should slope at least 3°.

## 1.5 Air connection

Screw the air hose into the air intake on the center block of the pump with for example a bayonet coupling. For best efficiency, use the same hose diameter as the internal diameter of the connection on the air intake.

# ▶ 1. INSTALLATION

## 1.5.1



### Air treatment system

The air valve is constructed for oilfree air. Lubrication of the air is **not allowed**. However, if the air is **very dry** (laboratory air), the air may be lubricated with water. Maximum air pressure is 8 bar. As prevention purpose, a filtration of the air by means of a 5 micron filter or finer is recommended. Dirt in the air can under unfortunate circumstances be the cause of breakdown. Recommended air quality according to PN-ISO8573 is particles class 3, water class 4 and oil class 3.

To facilitate the operation of the pump we recommend an air treatment system connected to the air supply. These components should be included:

- 1) Regulator to adjust the air pressure
- 2) Manometer to read the actual pressure
- 3) Needle valve to adjust the air flow
- 4) Filter

These components are included in Tapflos **Air treatment system** which can be ordered from us.

## 1.6 Example of installation

- 1) Gate valve compressed air
- 2) Filter and pressure regulator
- 3) Flexible hose
- 4) Needle valve
- 5) Flexible piping
- 6) Gate valve suction
- 7) Gate valve discharge
- 8) Coiled flexible piping
- 9) Flow gauge

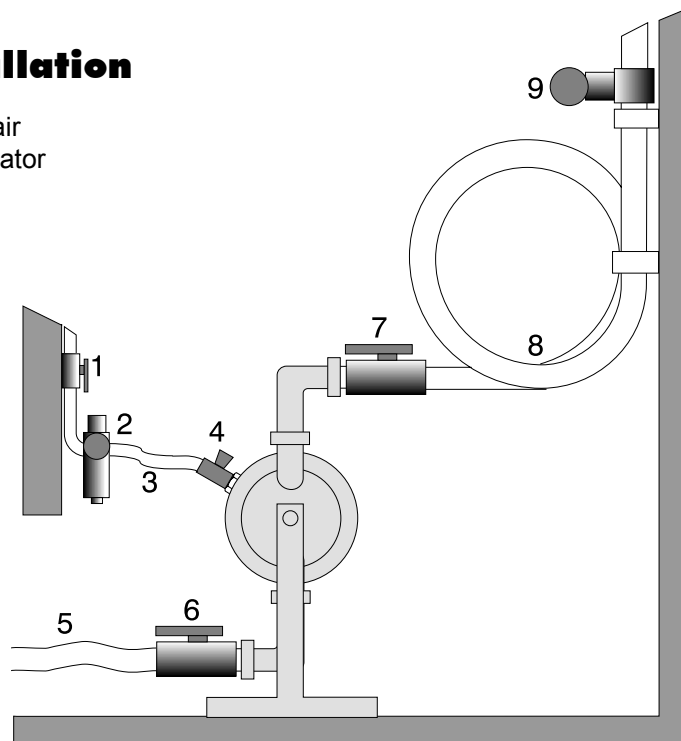

## 1.7 Recommended installations

The Tapflo pump is flexible in the way you are able to install it.

### 1.7.1 Flooded

The piping system is designed with a positive suction head. This is the best way of installation where it is necessary to completely evacuate all liquid from the container, or where viscous (thick) products are transferred.

### 1.7.2 Selfpriming

The Tapflo pump is designed to pull a high vacuum. It is able to evacuate an empty suction pipe without any damage to the pump. The suction lift is up to 5 meter (16.4 ') from an empty suction pipe and up to 8 meter (26.2') from a wetted pipe. The suction capability depends on the pump size (see chapter 5)

## ▶ 2. OPERATION

### 2.1 Health and safety

The pump must be installed according to local and national safety rules.



**The pumps are constructed for particular applications. Do not use the pump on applications different from that for which it was sold without consulting us to ascertain its suitability.**

#### 2.1.1 Protection



In the interest of health and safety it is essential to wear protective clothing and safety goggles when operating, and/or working in the vicinity of Tapflo pumps.

#### 2.1.2 Environments in danger of explosion



The standard stainless steel series pumps are not allowed to operate in environments in danger of explosion. Static electricity may occur in the pump under operation, which may cause explosion and injury. Special ATEX approved pumps are available for such applications. Consult Tapflo AB for further information. Follow the explosion safety rules applicable at the location for the pump.

#### 2.1.3 Air pressure

The maximum air pressure for Tapflo pumps is 8 bar. Higher air pressure than 8 bar can damage the pump and may cause injury to personel in vicinity of the pump. If you intend to apply a higher air pressure than 8 bar, please consult us.

#### 2.1.4 Noise level



At tests, the noise level from a Tapflo pump has not exceeded 80 dB(A). Under some circumstances, for example if the pump is operating under high air pressure at low discharge head, the noise can be inconvenient or hazardous for personel staying for long periods in vicinity of the pump. This hazard can be prevented by:

- using suitable ear protection
- lower the air pressure and/or raise the discharge head
- lead the outcomming air from the place by connecting a hose from the muffler connection of the pump.
- use elastomer valve balls (EPDM) instead of PTFE or stainless steel, provided that the elastomer is compatible with the pumped liquid.

#### 2.1.5 Temperature hazards

Raised temperature can cause damage on the pump and/or pipings and may also be hazardous for personel in the vicinity of the pump/pipings. Avoid quick temperature changes and do not exceed the maximum temperature specified when the pump was ordered. See also general max temperatures based on water in chapter 5 "Data".

### 2.2 Before starting the pump



- Make sure the pump is installed according to the installation instruction (section 1).
- Filling of the pump with liquid before start is not necessary.
- When installation is new or reinstalled, a test run of the pump with water should be conducted to make sure the pump operates normally and does not leak.

## ▶ 2. OPERATION

### 2.3 Starting and operating

- Open the discharge valve.
- *Note! Considering the suction capacity when air is still in the suction pipe, it is recommended to start with low air pressure/flow in the beginning. This is not necessary if the pump is filled with liquid before start.*
- When the pump has been filled with liquid, the air pressure/flow may be raised to increase the suction capacity of the pump.
- The performance of the pump can be adjusted through the air supply by using a needle valve and a pressure regulator. The performance can also be adjusted by normal flow control on the discharge side of the system.

#### 2.3.1 Dry running

The pump may run dry without any problem.

#### 2.3.2 Optimizing the pump lifetime

Running at full frequency (maximum air pressure/flow) continuously will cause premature wear of the components. As a general rule, we recommend to run at half of the maximum capacity of the pump. For instance, a T80 pump should run continuous maximum at 40 l/min.

### 2.4 Pump stopping

The pump can be stopped in two ways:

- 1) Close the discharge valve. The pressure from the system will stop the pump automatically. This will not do any damage to the pump. The pump restarts easy when the valve is opened again.
- 2) Stop the air supply.

### 2.5 Cleaning of the pump

#### 2.5.1 CIP - Clean in place

The importance of easy cleaning is especially great in hygienic and aseptic applications. Tapflo aseptic pumps are designed for CIP (clean in place). This allows the pump to be internally cleaned without strip down. The pump can be cleaned by flushing through with a CIP fluid (usually a mild solution of sodium hydroxide and a sanitizing additive) or by injection of hot steam. The CIP fluid temperature varies, but in the sanitary field, the temperature is usually about 90°C. Make sure that the CIP fluid is compatible with the materials in the pump/piping (consult us for further information).

The solution is passed through the system by either from the operation of the pump itself, or by a centralized cleaning system. The CIP fluid must pass through the pump at a minimum velocity of 1.5 m/s in the normal flow direction (from inlet to outlet).

##### 2.5.1.1 Drainage of the pump

After the CIP procedure, the pump usually has to be drained from the CIP fluid. The Tapflo aseptic series is supplied with a hygienic stand, enabling rotation of the pump unit for draining.

- 1) Disconnect the pump from the pipings.
- 2) Simply loosen the two domed nuts and rotate the pump and let the remaining fluid drain off.
- 3) Rotate back to normal position, connect the pump with the pipings and fix the domed nuts.

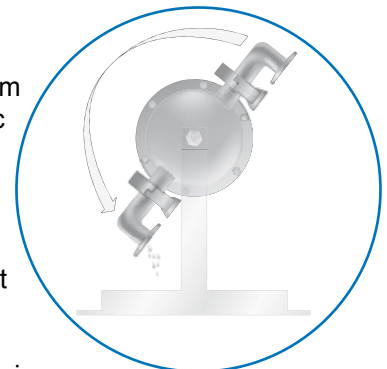

## ▶ 3. MAINTENANCE

### 3.1 Performance test

When installation is new, a test run of the pump should be conducted. Gauge the capacity at specific air pressure/flow. This information is for use in checking performance as wear takes place. You will be able to set schedules for maintenance of the pump and to select spare parts to be kept on stock.

### 3.2 Routine inspection



Frequent observation of the pump operation is recommended to detect problems. A change in sound of the running pump can be an indication of worn parts (see below "location of faults"). Leaking liquid from the pump and changes of performance may also be detected. Routine inspections should be conducted frequently.

### 3.3 Complete inspection



The intervals for a complete inspection depend upon the operation conditions for the pump. The characteristics of the liquid, temperature, materials used in the pump and running time decide how often a complete inspection is necessary.

If a problem has occurred, or if the pump is in need of a complete inspection, see later this chapter "location of faults" and "dismantling of the pump". You are of course warmly welcome to consult us for further help.

Worn parts should be carried in stock, see our recommendation in chapter 4.

### 3.4 Location of faults

Problem	Possible fault
The pump does not run	The air pressure is too low The air connection is blocked Muffler is blocked Air valve is defect Dirt in the pump chamber Diaphragm breakdown
The suction is bad	Suction connection is not tight Suction connection is blocked Muffler is blocked Valve balls are blocked Valve balls are damaged
The pump runs irregularly	Valve balls are blocked Sealings are defect in air valve or center block Diaphragm breakdown
Bad flow/pressure	Pressurefall in incoming air Suction or air connection blocked Muffler is blocked Air valve is defect Valve balls worn out/broken Air in liquid Diaphragm breakdown
Liquid leaks from the pump	Screws on the housing not properly fastened
Liquid comes out of the muffler	Diaphragm breakdown

## ▶ 3. MAINTENANCE

### 3.7 Dismantling the pump

#### 3.7.1 Before the dismantling procedure



Be sure to drain all liquid from the pump. Cleanse or neutralize the pump thoroughly. Disconnect the air connection and then the suction and discharge connections. Place the pump on a clean soft surface and use suitable gloves to avoid fingerprints and contamination of the pump.

The numbers put in brackets refer to the positions on the assembly drawing.

#### 3.7.2 Mainparts

- 1) Unscrew and remove the clamps (138) from the pump. Carefully remove the manifolds (131 and 132), valve ball stops (22), valve balls (23) and o-rings (18).
- 2) Unscrew the domed nuts (174) and lift off the pump unit from the support (17).
- 3) Unscrew and release the domed nuts (37) from one side of the pump. Place the pump with the housing (11) that still has the nuts on downwards. Then lift off the loose housing from the centerblock unit and then carefully pull the centerblock unit from the remaining housing with pin screws (14).

#### 3.7.3 Center block

- 1) Press the diaphragms (15) to their neutral position (both have the same distance to the center block).
- 2) Hold one of the diaphragms and unscrew the other. Then pull out the remaining diaphragm with the diaphragm shaft (16).
- 3) Place the center block on a clean place. Observe that this is a faying surface, so be careful not to damage it. Pull out the circlip (27) carefully with pliers so it will not hurt you or disappear.
- 4) Turn the center block. Pull out the other circlip (27).
- 5) Press carefully out the air valve from the housing. The main piston and air valve housing will slowly come out. Observe that the brass is soft material and changes figure easy. If those details are deformed they must be changed, so handle those with care.

The pump is now completely dismantled. Check all components for wear or damage and replace if necessary.

## ▶ 3. MAINTENANCE

### 3.8 Assembly of the pump

#### 3.8.1 Center block

- 1) Mount the circlip (27) on one side. Put some soft soap solution on the air valve o-rings (30) and then carefully push the air valve (61) into the housing. It is recommended to use a pressing device for this operation. Make sure that the o-rings (30) remain in the right position. Put the circlip (27) on the other side.
- 2) Fix securely the pin bolts from the diaphragm shaft (16) in the diaphragms (15)
- 3) Put the diaphragm (15) with shaft (16) into the center block. Screw the next diaphragm (15) onto the shaft (16) and fix the holes. Sometimes you have to turn the diaphragms a little back to get the holes fixed.

#### 3.8.2 Assembling of the main units

The housing is assembled in opposite order to dismantling.

- 1) Make sure all pin screws (14) have a domed nut (37) each. Nut should only be put on one or two threads.
- 2) Place one of the housings (11) on the centerblock and then gently put all the pin screws through the housing and centerblock. Be careful so that threads on screws do not damage the diaphragms when assembling.
- 3) Put on the remaining housing (11) onto the pin screws (14).
- 4) Fasten the domed nuts (37) by hand, then fasten alternatingly with a tool. After a few weeks operation a follow up draft of the nuts is recommended.
- 5) Place the pump unit on the support and fasten the domed nuts (174) only by hand, so that the pump unit can be turned.
- 6) Turn the pump unit until the inlet side is upwards. Place the o-rings (18), valve ball stops (22), valve balls (23) and then the inlet manifold (131) on the housing inlets.
- 7) Mount and fasten the clamps (138).
- 8) Turn the pump unit and do the same procedure on the outlet side as described in step 6. Fasten the domed nuts (174).

The pump is now ready for service and can be reinstalled in the system according to section 1 and 2 (installation and operation).

#### 3.8.3 Test run

We recommend you to conduct a test run of the pump before installing it to the system so no liquid gets wasted if the pump leaks or perhaps does not start according to wrong assembling of the pump.

## 4. SPARE PARTS

### 4.2 TX94 and TX144 - Drawing and spare part list

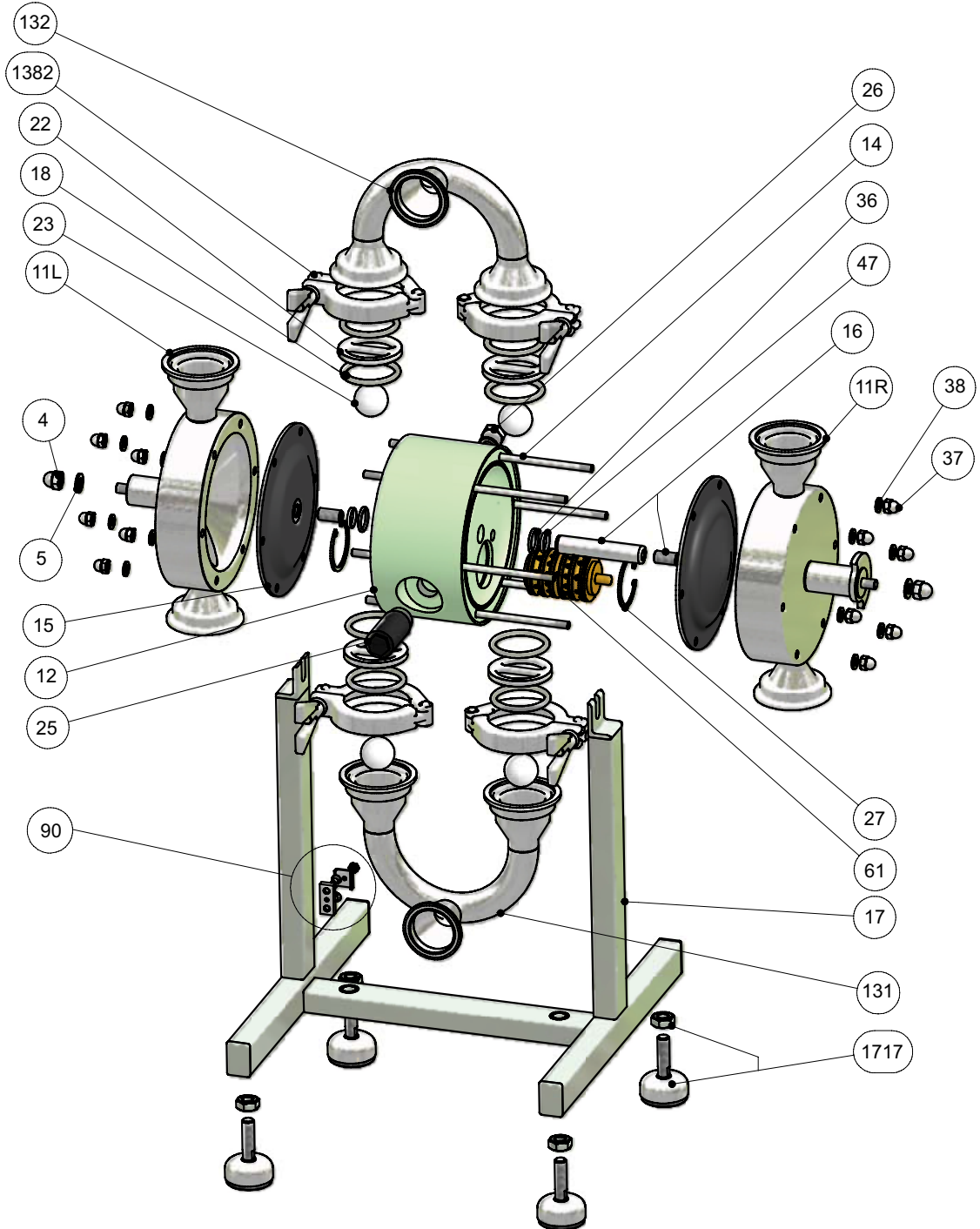

Pos	Description	Qty	Pos	Description	Qty
4	Domed nut	2	18	O-ring	8
5	Washer	2	22	Valve ball stop	4
11L	Housing left side	1	23	Valve ball	4
11R	Housing right side	1	25	Muffler	1
12	Center block	1	26	Air intake adapter	1
131	Manifold inlet	1	27	Circlip	2
132	Manifold outlet	1	30	O-ring	6
1382	3-clamp	4	36	Center block sealing	2
14	Pin screw	6	37	Domed nut	12
15	Diaphragm	2	38	Washer	12
16	Diaphragm shaft	1	47	O-ring (back up for 36)	2/4*
17	Stand	1	61	Air valve complete	1
1717	Adjustable foot set	4	90	Earth connection kit	1

\* = TX144 only

## ▶ 4. SPARE PARTS

### 4.3 Stocking recommendation

Even at normal operation some details in the pump will be worn. In order to avoid expensive breakdowns we recommend having a few spare parts in stock.

Depending on the severity of the operation and the importance of not having a breakdown we offer two different spare part sets. When ordering a spare part set, the complete pump model number must be given to us (see this page "pump code").

Spare part set No 1

Qty	Description	Pos
2	Diaphragm	15
4	Valve ball	23
1	Muffler	25
8	O-ring	18

Spare part set No 2

Qty	Description	Pos
1	Spare part set No 1	-
1	Diaphragm shaft	16
2	Circlip	27
2	Center block seal	36
2/4*	O-ring	47
1	Air valve complete	61

\* = TX144 only

### 4.4 How to order parts

When ordering spare parts for Tapflo Pumps, please let us know the **model number** from the nameplate of the pump. Then just indicate the part numbers (referred to the spare part list) and quantity of each item.

### 4.5 Pump code

The model number on the pump and on the front page of this instruction manual tells the pump size and materials of the pump components.

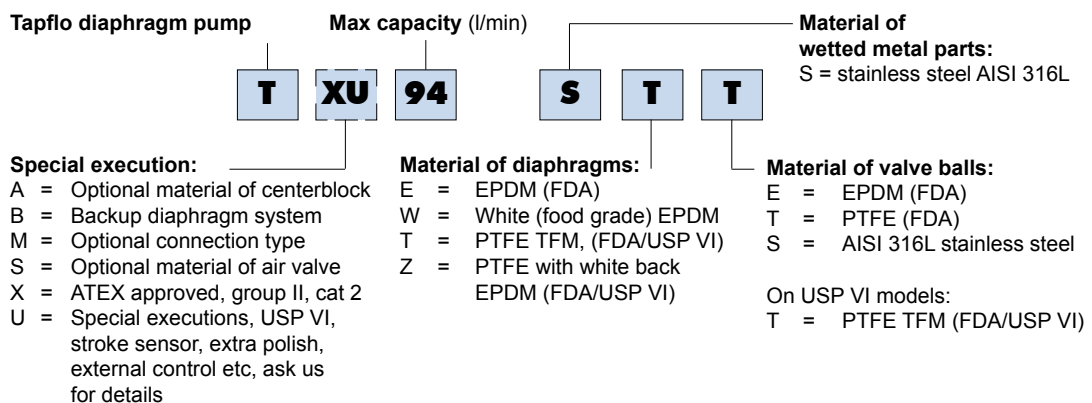

# 5. DATA

## 5.1 Capacity curves

The performance curves are based on water at 20°C. Other circumstances might change the performance. See below how the capacity will change at different viscosities and suction lifts.

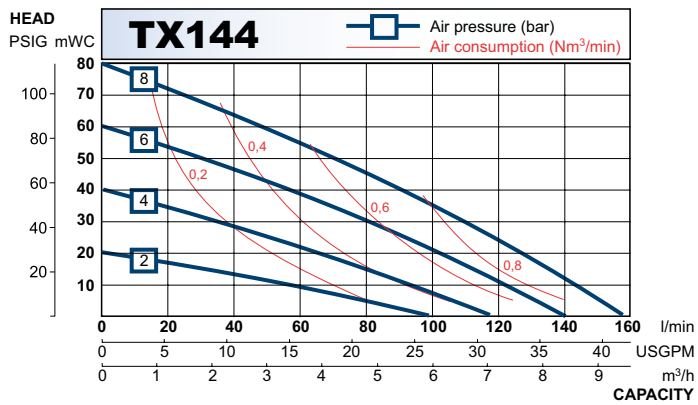
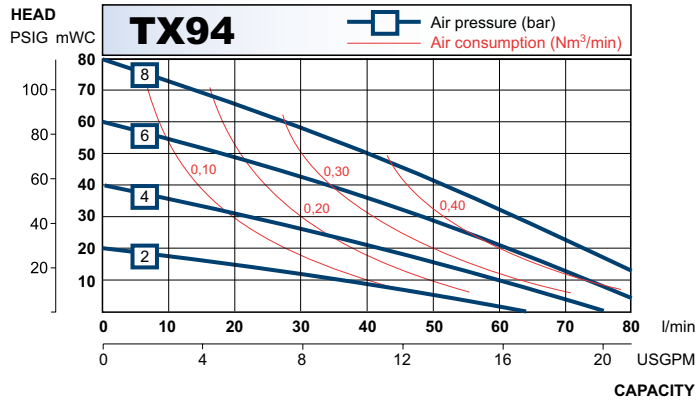

Recommended flow is half of the the max flow, i.e. recommended flow for a TX94 is 47 l/min.

## 5.2 Capacity changes

Capacity changes at different suction lifts

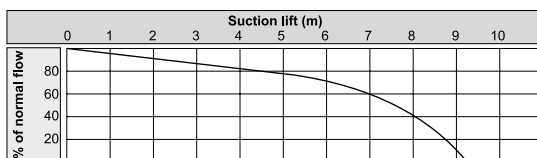

Capacity changes at different viscosities

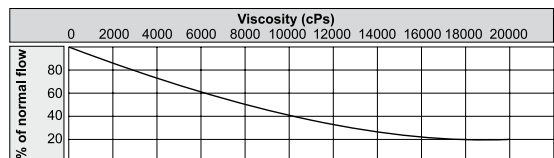

## 5. DATA

### 5.3 Dimensions and technical data

Data		
Model	TX94	TX144
Max flow	94 l/min	144 l/min
Max pressure	8 bar	8 bar
Max air pressure	8 bar	8 bar
Dry suction lift	2 m	3 m
Max solid size	6 mm, bigger if soft	6 mm, bigger if soft
Temperature	-20° .... +110°C (temporary higher)	
Weight	15 kg	22 kg
Connections	Triclamp (standard), SMS, DIN and RJT threads, DIN 11864 clamp	
ATEX details	Group II, cat 2, T4	

#### Materials and options

Housing, manifolds	AISI 316L, Ra 0.8 Ra 0.5 on request
Diaphragms	PTFE (FDA & USP VI) EPDM (FDA on request) White EPDM (FDA) PTFE with white back (FDA & USP VI)
Valves (ball type)	PTFE (FDA) PTFE (USP VI & FDA) EPDM (FDA on request) AISI 316L
O-rings	EPDM (FDA) EPDM (USP VI & FDA) FEP/FKM (FDA)
Options	Backup diaphragm system

#### Dimensions (mm)

A	260	280
B	275	278
E	447	488
H	185	188
J	DN 40	DN 50

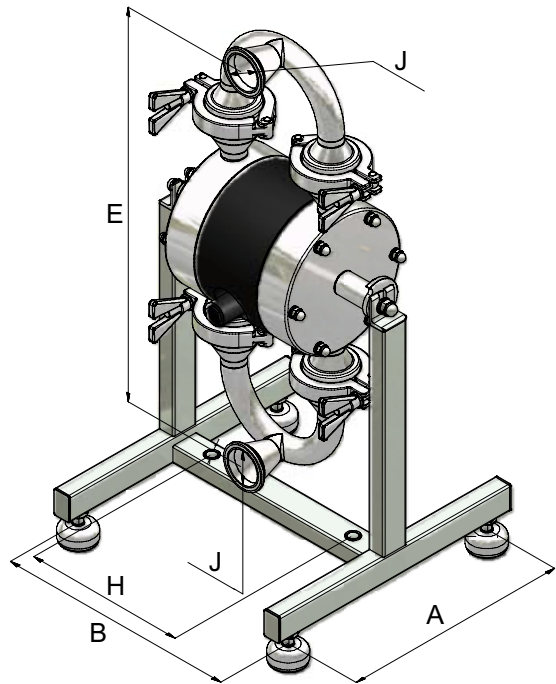

### 5.4 Tightening torques

The following tightening torques are recommended.

Pump size	Mounting torque (Nm)
TX94	8
TX144	16

## ▶ 6. WARRANTY & REPAIR

### 6.1 Returning parts

When returning parts to Tapflo AB please follow this procedure:

- Consult Tapflo AB for shipping instructions.
- Cleanse or neutralize and rinse the part/pump. Make sure the part/pump is completely empty from liquid.
- Pack the return articles carefully to prevent any damage under transport.

***Goods will not be accepted unless the above procedure has been complied with.***

### 6.2 Warranty

Tapflo warrants products under conditions as below for a period of not more than 12 months from installation and not more than 24 months from date of manufacture.

1. The following terms and condition apply to the sale of machinery, components and related services and products, of Tapflo (hereinafter “the products”)
2. Tapflo (the manufacturer) warrants that:
  - a.) its products as being free of defects in material, design and workmanship at the time of original purchase;
  - b.) its products will function in accordance with Tapflo operative manuals; Tapflo does not guarantee that the product will meet the precise needs of the Customer, except for those purposes set out in any invitation to render documents or other documents specifically made available to Tapflo before entering into this agreement;
  - c.) high quality materials are used in the construction of the pumps and that machining and assembly are carried out to the highest standards.

Except as expressly stated above, Tapflo makes no warranties, express or implied, concerning the products, including all warranties of fitness for a particular purpose.

3. This warranty shall not be applicable in circumstances other than defects in material, design, and workmanship. In particular warranty shall not cover the following:
  - a.) Periodic checks, maintenance, repair and replacement of parts due to normal wear and tear (seals, O-rings, rubber items, bushings, etc.);
  - b.) Damage to the product resulting from:
    - b.1.) Tampering with, abuse or misuse, including but not limited to failure to use the product for its normal purposes as stated at the time of purchase or in accordance with Tapflo instructions for use and maintenance of the product, or the installation or improper ventilation or use of the product in a manner inconsistent with the technical or safety standard in force;
    - b.2.) Repairs performed by non skilled personell or use of non original Tapflo parts
    - b.3.) Accidents or any cause beyond the control of Tapflo, including but not limited to lightning, water, fire, earthquake, and public disturbances, etc.;
4. The warrantee shall cover the replacement or repairing of any parts, which is documentedly faulty due to construction or assembling, with new or repaired parts free of charges delivered by Tapflo. Parts subjected to normal tear and wear shall not be covered by the warranty. Tapflo shall decide as to whether the defective or faulty part shall be replaced or repaired.
5. The warrantee of the products shall be valid for a period in accordance to the current law from the date of delivery, under the condition that notice of the alleged defect to the products or parts thereof be given to Tapflo in written within the mandatory term of 8 days from the discovery.

## ▶ 6. WARRANTY & REPAIR

---

- 6 Repair or replacement under the terms of this warranty shall not give a right to an extension to, or a new commencement of, the period of warranty. Repair or replacement under the terms of this warranty may be fulfilled with functionally equivalent reconditioned units. Tapflo qualified personnel shall be solely entitled to carry out repair or replacement of faulty parts after careful examination of the pump. Replaced faulty parts or components will become the property of Tapflo
- 7 The products are built in accordance with standard CE normative and are tested (where applicable) by Tapflo. Approval and tests by other control authority are for the customers account. The products shall not be considered defective in materials, design or workmanship if they need to be adapted, changed or adjusted to conform to national or local technical or safety standards in force in any country other than that for which the unit was originally designed and manufactured. This warranty shall not reimburse such adaptations, changes or adjustments, or attempt to do so, whether properly performed or not, nor any damage resulting from them, nor any adaptation, change or adjustments to upgrade the products from their normal purpose as described in the products operative manual without the prior written consent of Tapflo
- 8 Installation, including electric and other connections to utility mains according to Tapflo drawings, is for the cost and responsibility of the customer, unless otherwise agreed in writing.
- 9 Tapflo will not be liable on any claim, whether in contract, tort, or otherwise, for any indirect, special, incidental, or consequential damages, caused to the customer or to third parties, including loss of profits, arising by any possible infringement of par. 3 above or by the customer or third parties being in the impossibility of using the products.

Steady the above, Tapflo liability to the customer or third parties from any claim, whether in contract, tort, or otherwise, shall be limited to the total amount paid by the customer for the product that caused the damages.



A large grid of graph paper for taking notes, consisting of 20 columns and 30 rows of small squares.



Tapflo AB · Filaregatan 4 · S-442 34 Kungälv · Sweden  
Tel (46) 303 63390 · Fax (46) 303 19916 · E-mail: [sales@tapflo.com](mailto:sales@tapflo.com) · [www.tapflo.com](http://www.tapflo.com)

---

DISTRIBUTOR: