

PT 10 - 20

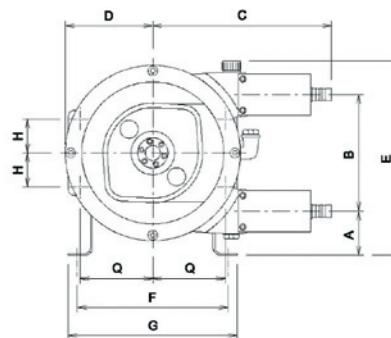

PT 25 - 40

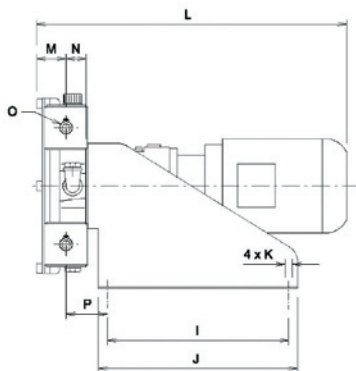
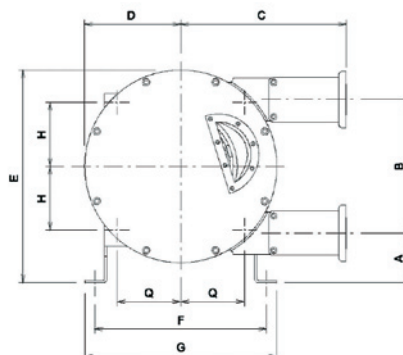
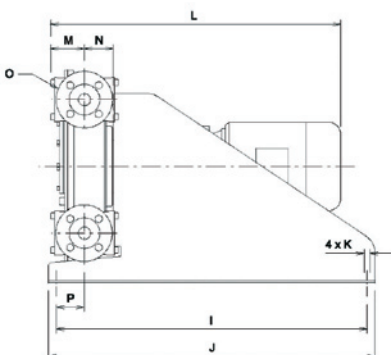

PT 65 - 125  
PTX 40 & 80

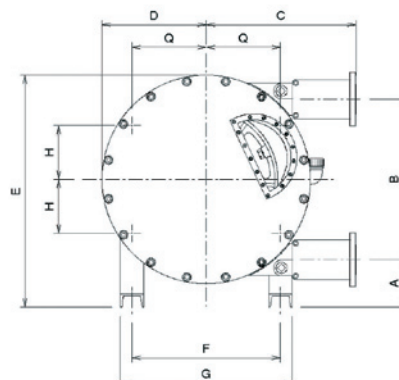
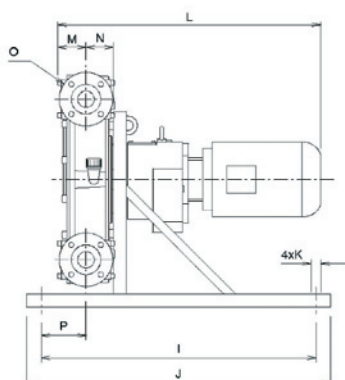

## Dimensions

TYPE	A	B	C	D	E	F	G	H	I	J	K	L	M	N	O	P	Q
PT 10	103,5	115	226	95	256	220	240	33,5	260	280	4xø9	-	46,5	26	ø16 *	56	81,25
PT 15	73	193	296	145	322	250	280	51,75	300	330	4xø13	-	49	33,5	ø20 *	68,8	124,75
PT 20	73	193	296	145	322	250	280	51,75	300	330	4xø13	-	49	33,5	ø25 *	68,8	124,75
PT 25	95	262	355,5	190	416	311	351	110	560	600	4xø13	-	65	79	DN25 PN16	61	110
PT 32	122,5	330	435,5	238	525,5	426	476	157,75	770	810	4xø13	-	83	71	DN32 PN16	109	157,75
PT 40	122,5	330	435,5	238	525,5	426	476	157,75	770	810	4xø13	-	83	71	DN40 PN16	109	157,75
PTX 40	110	430	400	291	616	340	420	170	850	950	4xø19	-	75	88	DN40 PN16	87	170
PT 65	164,5	554	517,5	360	801,5	513	593	186,5	950	1050	4xø19	-	94,5	98	DN65 PN16	152	256,5
PT 80	154	748	604	473	1004	580	680	290	1150	1250	4xø19	-	129	133	DN80 PN16	117	290
PTX 80	262	876	803	55	1320	690	830	345	1300	1400	4xø27	-	140,5	145	DN80 PN16	210	345
PT 100	300	1040	887	685	1680	820	960	410	1900	2000	4xø27	-	149	220	DN100 PN16	295	410
PT 125	263,5	1273	1038	785	1750	1000	1140	500	1900	2000	4xø27	-	300	232	DN125 PN16	660	500

\* hose bard connections

# FLOW RATE (L/h)



TYPE	20 RPM	40 RPM	60 RPM	80 RPM	100 RPM
PT 10	30	60	90	120	150
PT 15	100	200	300	400	500
PT 20	170	340	500	670	850
PT 25	400	800	1 200	1 600	2 000
PT 32	750	1 500	2 250	3 000	
PT 40	1 170	2 340	3 510		
PTX 40	1 600	3 200	4 800		
PT 65	4 600	9 200	13 800		
PTX 80	11 000	22 000			

TYPE	10 RPM	20 RPM	30 RPM	40 RPM
PT 80	7 000	14 000	21 000	28 000
PT 100	12 000	24 000	36 000	48 000
PT 125	22 000	44 000	66 000	

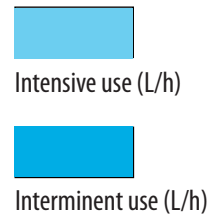

## Tapflo PT PUMP HOSE

It is made by weaving layers of rubber material and weaves of synthetic or metallic fibers over each other to form a tube.

Tapflo PT Hose construction:

- \* Inner liner
- \* Reinforcement layers ( 2 - 6 )
- \* Cover

For the hose liner 3 materials are available to suit the diversity of pumped products:

- NR (natural rubber)      Abrasive fluids
- NBR (Buna)              Oily fluids
- EPDM                      Acid & corrosive fluids

NR hose has a life span which is Double than EPDM and Triple than NBR. (if possible)

How to use the curves:

- 1 Select the required flow. This gives you the required pump speed.
- 2 Move upwards to the calculated discharge pressure.
- 3 Move to the left for the installed motor power.
- 4 Determine the fluid's max. temperature.
- 5 Move to the left to the calculated discharge pressure.
- 6 Move downwards to determine your maximum allowed pump speed for the fluids temperature.

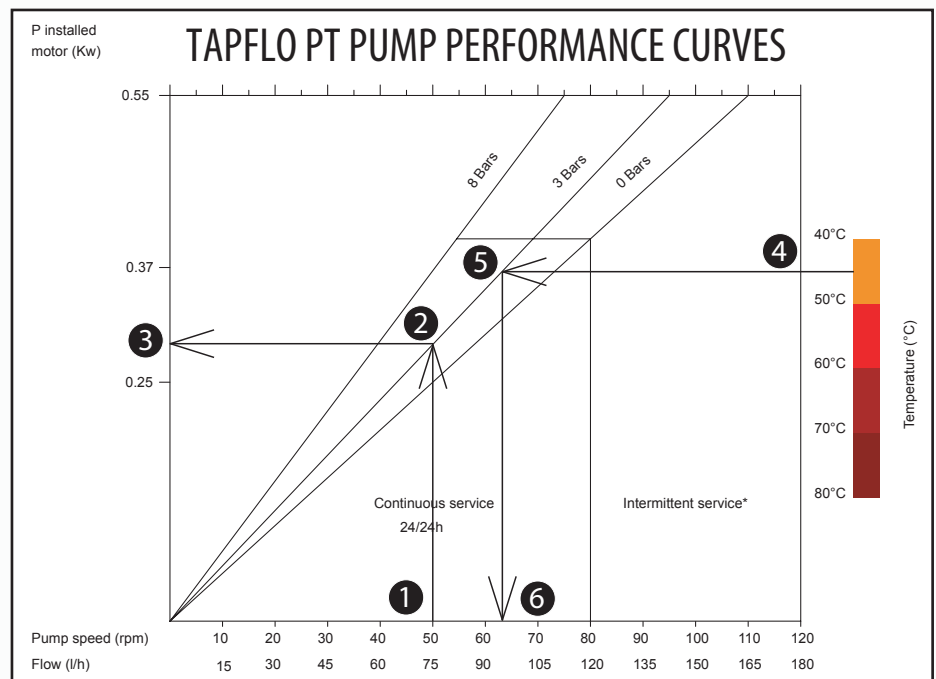

# TAPFLO PT PUMP PERFORMANCE CURVES

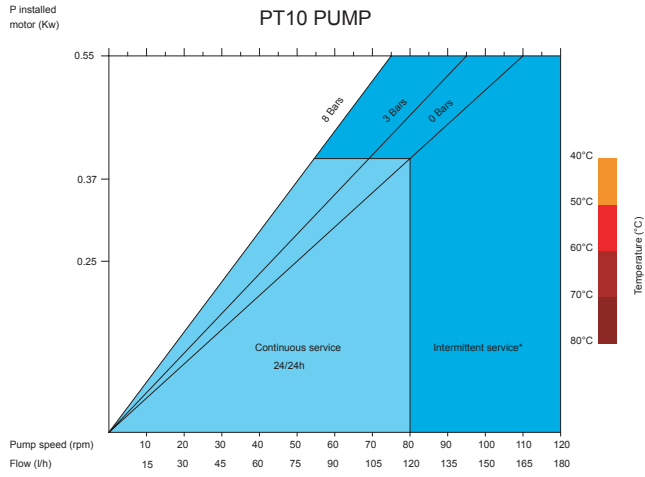

\*Intermittent use is 2hrs max. continuous duty followed by 1hr stop.

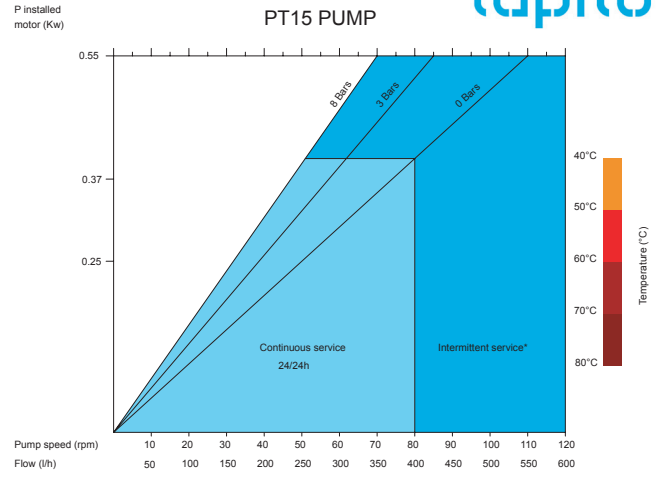

\*Intermittent use is 2hrs max. continuous duty followed by 1hr stop.

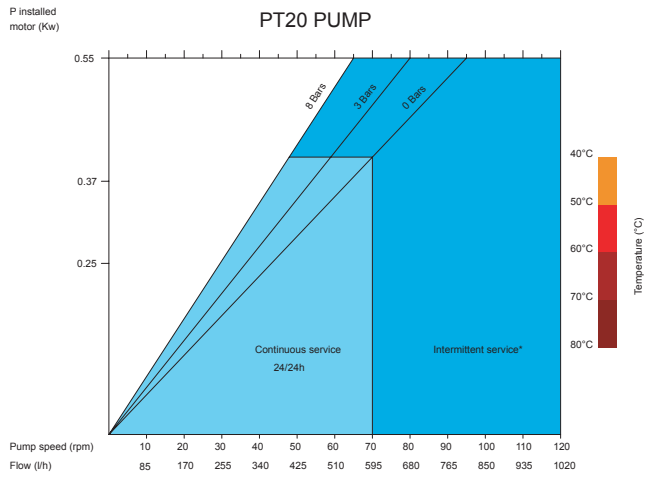

\*Intermittent use is 2hrs max. continuous duty followed by 1hr stop.

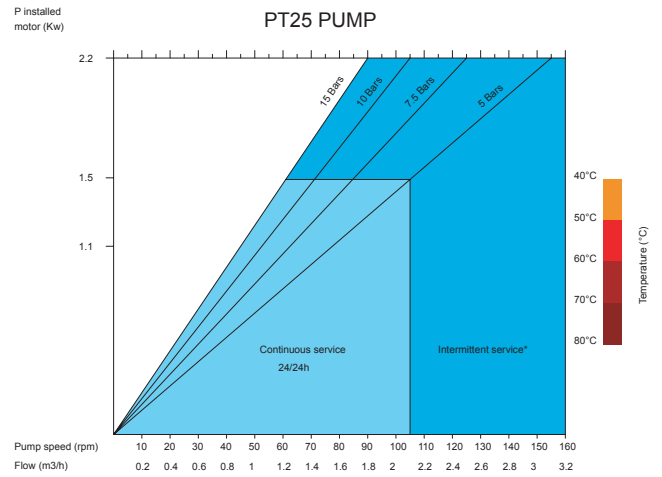

\*Intermittent use is 2hrs max. continuous duty followed by 1hr stop.

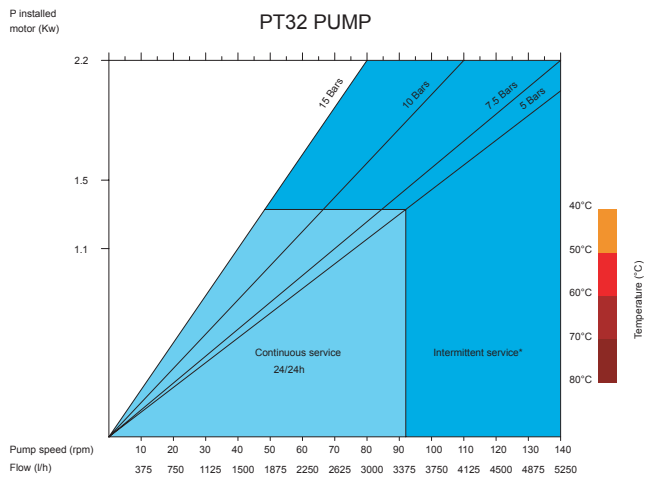

\*Intermittent use is 2hrs max. continuous duty followed by 1hr stop.

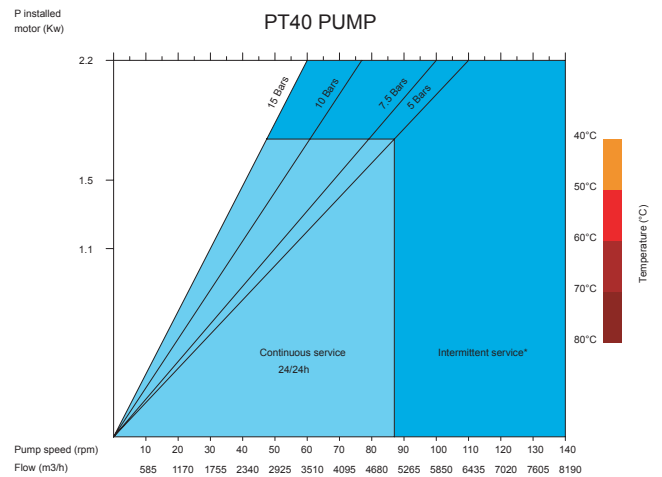

\*Intermittent use is 2hrs max. continuous duty followed by 1hr stop.

# TAPFLO PT PUMP PERFORMANCE CURVES

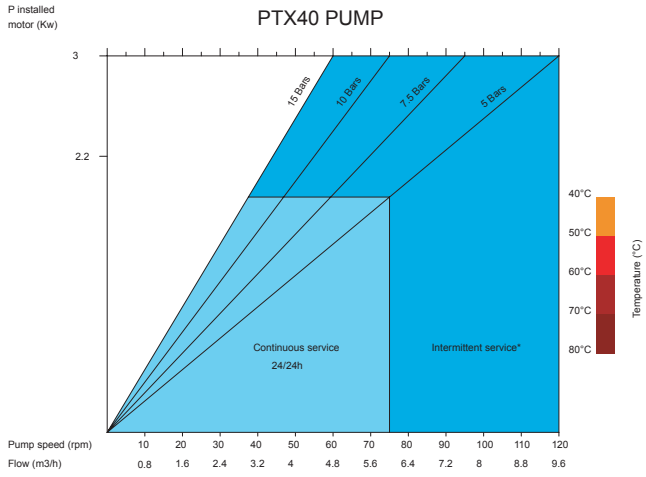

\*Intermittent use is 2hrs max. continuous duty followed by 1hr stop.

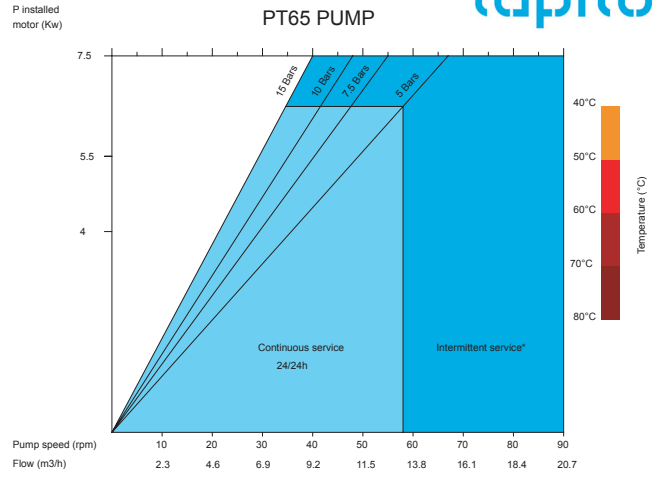

\*Intermittent use is 2hrs max. continuous duty followed by 1hr stop.

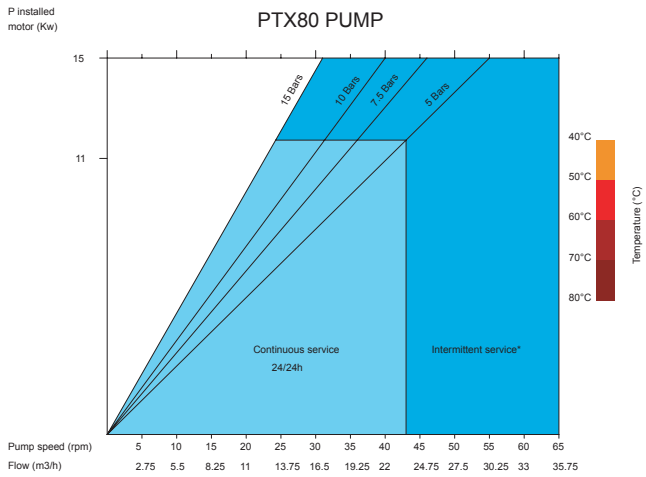

\*Intermittent use is 2hrs max. continuous duty followed by 1hr stop.

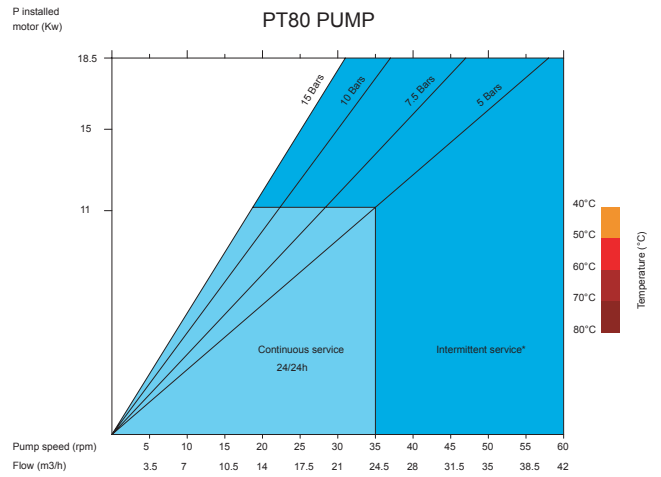

\*Intermittent use is 2hrs max. continuous duty followed by 1hr stop.

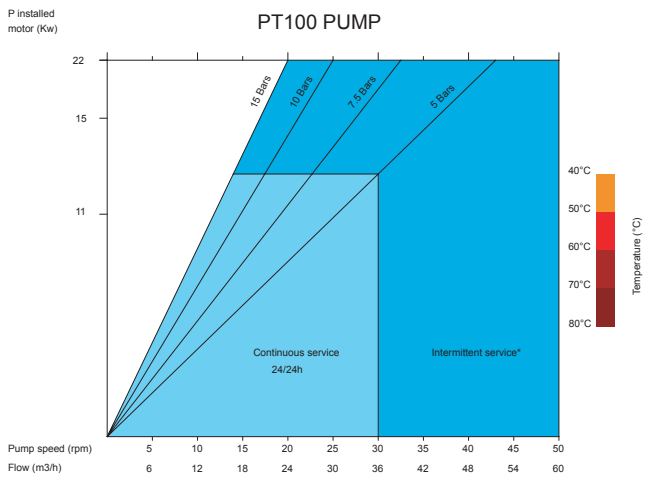

\*Intermittent use is 2hrs max. continuous duty followed by 1hr stop.

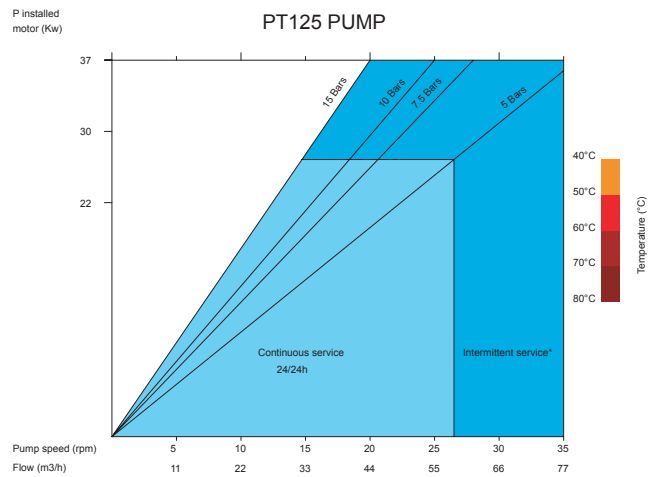

\*Intermittent use is 2hrs max. continuous duty followed by 1hr stop.